

AUSFÜHRUNG DER BOHRUNG BITTE ANKREUZEN UND MAßE EINTRAGEN:

Vorgebohrt:	Passfedernut:	Passfedernut m.Klemmschraube	Nur Klemmschraube																				
																							
d = mm	<table border="1" style="margin-left:auto; margin-right:auto;"> <tr><td>B =</td><td>mm</td></tr> <tr><td>d =</td><td>mm</td></tr> <tr><td>L =</td><td>mm</td></tr> </table>	B =	mm	d =	mm	L =	mm	<table border="1" style="margin-left:auto; margin-right:auto;"> <tr><td>B =</td><td>mm</td></tr> <tr><td>d =</td><td>mm</td></tr> <tr><td>L =</td><td>mm</td></tr> <tr><td>M =</td><td></td></tr> </table>	B =	mm	d =	mm	L =	mm	M =		<table border="1" style="margin-left:auto; margin-right:auto;"> <tr><td>alpha =</td><td>mm</td></tr> <tr><td>d =</td><td>mm</td></tr> <tr><td>M =</td><td></td></tr> </table>	alpha =	mm	d =	mm	M =	
B =	mm																						
d =	mm																						
L =	mm																						
B =	mm																						
d =	mm																						
L =	mm																						
M =																							
alpha =	mm																						
d =	mm																						
M =																							

Einzelheit "z" / M2:1

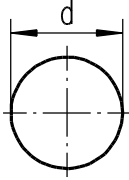

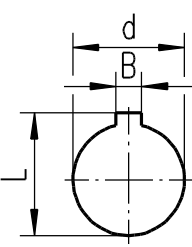
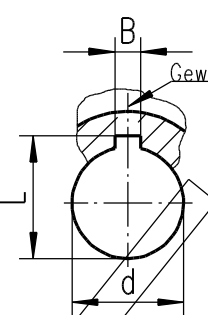
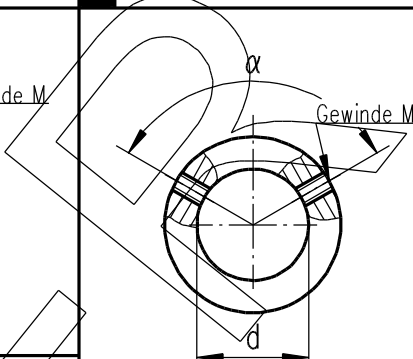
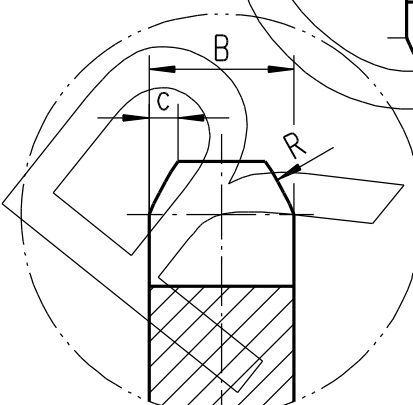
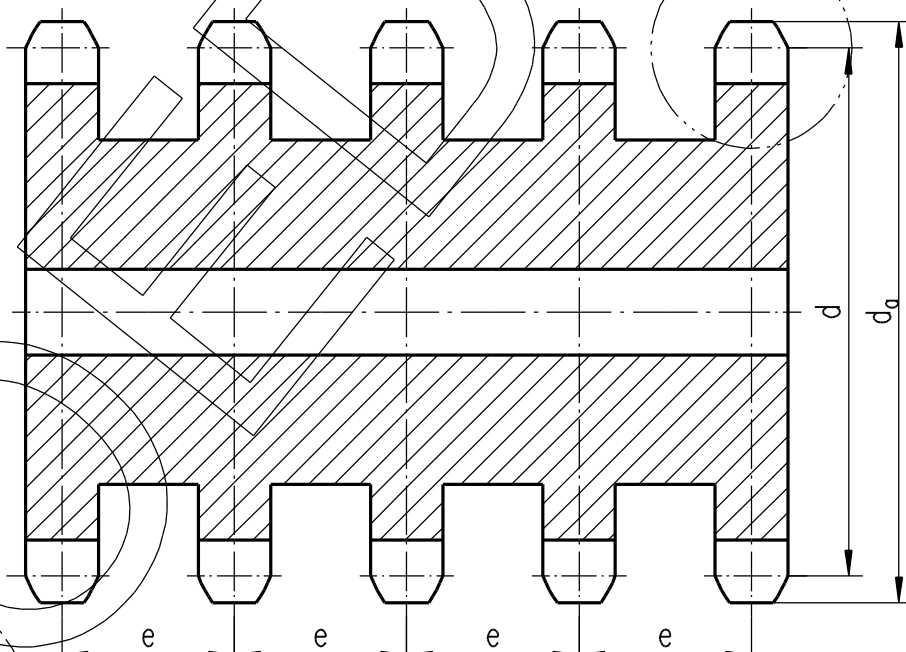

B =	mm
c =	mm
d =	mm
e =	mm
da =	mm
R =	mm
Für Kette :	

 ROEDER KETTENTECHNIK		Allgemeintoleranzen DIN ISO 2768 T1 m DIN ISO 2768 T2 K		Maßstab 1:1 (Gewicht)	
				Datei: KRS_5.dcd	
		Datum		Name	
		Bearb. 02.09.04		Heinrichs	
		Gepr.		Fünffach-Kettenradscheibe	
		Norm			
				Zeich.-nr.: _____	
				Blatt	
				Blätter	
Zust.	Änderung	Datum	Name	Urspr.	Ers. für:
					Ers. durch:

I:\Zeichnungen_Documente_Kunde\Vorlagen\11 Kettenräder\KRS_5.dcd